



THE RESEARCH AND PRODUCTION ENTERPRISE

SAFE MEANS AND SYSTEMS
OF TECHNOLOGICAL MONITORING

MEASURING INSTRUMENT - TECHNOLOGICAL REGULATOR (UNIVERSAL MILLI -VOLTMETER)

IPT 1730D/M

Manual

НКГЖ.411618.003-05ПС



Инв. № подл.	Подп. и дата
Взаим инв. №	Инв. № дубл
Подп. и дата	Подп. и дата

Contents

1. Use.....	3
2. Specifications and characteristics.....	5
3. Completeness.....	11
4. Device and its operation	12
5. Instruction of security measures.....	22
6. Preparation for work.....	23
7. The operating procedure.....	24
8. Technique of check.....	24
9. Guidelines of transportation and keeping.....	39
10. Certificate on packing.....	40
11. Acceptance certificate.....	41
12. Resources, service life and shelf manufacturer's guaranties (supplier's guaranties).....	42
Appendix A.	43
Appendix Б	44

1. USE

The measuring instrument - technological regulator (universal milli-voltmeter) IPT 1730D/M (further IPT 1730D/M) is intended for measurement and control of temperature and other not electrical sizes transformed into the electrical signals of force and voltage of the direct current and the active resistance to the direct current.

IPT 1730D/M (increased reliability) is used in a structure of control systems of technological processes both in industry.

IPT 1730D/M is over configured as an input signal, the ranges of the size being measured and a scale type.

IPT 1730D/M has a digital indication of the current value of the parameter being measured, the digital values of the bottom and top settings, and also a scaled indication displaying graphically and being measured with color.

The executive relays of the channels of the signal system provide the switching of:

- the alternating current of the network frequency:
 - at the voltage of 250V up to 5 A for the active loading,
 - at the voltage of 250 V up to 2 A for the inductive loading ($\cos \varphi \geq 0,4$);
- the direct current:
 - at the voltage of 250V up to 0,1 A fir the active and inductive loading,
 - at the voltage of 30V up to 2A for the active and inductive loading.

Note. It is recommended that the setting of extinguishing of flashes of the chains should be done at the inductive loading. The extinguishing chain of flashes is supposed to include the consistent connected resistor 50...100 Ohm, 0,5 W and the condenser 10...100 nF for the voltage not less than 630 V.

IPT 1730D/M includes the measuring built-in converter (MBC), converting the size being measured into the unified output signal of the direct current force, the built-in voltage stabilizer intended for powering of the initial converters with a unified output signal of the direct current force.

The dependence of the size being measured of IPT 1730D/M and the output signal of the MBC on the input signal can be linear and for the configurations with the input unified signals - with a function of the square root extraction.

IPT 1730D/M correspond to climatic modification T3 according to all-Union State Standard 15150-69.

For the security against the influence of the environment according to

- All-Union State Standard 15150-69, IPT 1730D/M is made in an anticorrosive fulfillment T III;
- **all-Union State Standard 15150-69, IPT 1730D/M is made in a non-corrosive climatic modification T3 at the following maintenance of the active corrosive agents in the atmosphere:**
 - chlorides - 0,02 mg/m³,**
 - sulfates - 0,03 mg/m³,**
 - sulphurous gas - 0,03 mg/m³;**
- All-Union State Standard 14254-96 protection degree against penetrating into IPT 1730D/M of firm bodies and water for
 - the front panel IP54;
 - the case IP20,

According to all-Union State Standard 25804.1-83, IPT 1730D/M:

- concerns to category Б - the equipment of the continuous application
- concerns to kind I about the number of quality degrees of functioning and has two quality degrees of functioning - a nominal level and refusal.

According to НП-001-97 (ОПБ-88/97) IPT 1730D/M corresponds to

- the elements of the normal operation – on use;
- the important elements for safety – on influencing the safety;
- the managing elements – on the type of the executing functions.

IPT 1730D/M correspond to execution group M6 on stability against any mechanical influences while operating according to all-Union State Standard 17516.1-90.

IPT 1730D/M correspond to category I of seismic stability according to НП-031-01 and to group Б of execution 3 on РД 25 818-87.

IPT 1730D/M is proof, strong and steady against influencing of earthquake with a level of seismicity of 8 points on MSK-64 scale at the installation level above a zero mark up to 40 m according to all-Union State Standard 25804.3-80.

IPT 1730D/M corresponds to execution group III according to all-Union State Standard P 50746-2000, The quality criterion of functioning - A.

2. Specifications and characteristics

2.1. The ranges measurements and transformation, the input parameters and the limits of the admitted basic given error in view of configurations of IPT 1730D/M correspond to the given ones in tables 2.1 and 2.2.

Table 2.1 - IPT 1730D/M with the input signals from the resistance thermo-converters (RT) and the thermo-electrical converters (TC)

Size being measured	Type of the initial converter	W_{100}	Range of measurements, °C	Input parameters			Limits of the admitted basic given error about HCX, %	
				on HCX		Input resistance, kOhm		
				Resistance, Ohm	Thermal electromotive force, mV			
Temperature, °C	50M	1,4280	-50÷+200	39,23÷92,78	-	-	±(0,25 + *)	
	100M			78,45÷185,55				
	50M	1,4260		39,35÷92,62				
	100M			78,69÷185,23				
	50Π	1,3910		40,00÷88,53				
	100Π			80,00÷177,05				
	Pt100	1,3850	80,31÷175,86					
	50Π	1,3910	-50÷+600	40,00÷158,585			not less 100	±(0,25 + *)**
	100Π			80,00÷317,17				
	Pt100			80,31÷313,71				
	TXA XA(K)	-	0÷1300	0÷52,410				±(0,5 + *)
	TXK XK(L)		0÷600	0÷49,108				
	ТПП ΠΠ(S)***		0÷1700	0÷17,947				
	TBP BP (A-1)***		0÷2500	0÷33,640				
ТПП ΠΠ(B)***	300÷1800		0,431÷13,591					

* – one unit of the last category expressed in the percentage of a range of measurements

** – excluding the sub-range (-50÷+200) °C

*** – by the separate order

Table 2.2 – IPT 1730D/M with input signals as force or voltage of a direct current.

Input signal	Range of transformation	Range of measurements		Input resistance, kOhm		Limits of the admitted basic given error, %
		for dependence of measured sizes on an input signal:		not less	no more	
		linear	with the function of extraction of a square root			
Current	0÷1 mA***	0÷1 mA***	0,02÷1 mA***	-	0,1	± (0,2+*)
	-1÷0÷1 mA***	-1÷0÷1 mA***	-0,96÷+1 mA***			
	0÷5 mA	0÷5 mA	0,1÷5 mA		0,01	
	-5÷0÷5 mA	-5÷0÷5 mA	-4,8÷+5 mA			
	0÷20 mA	0÷20 mA	0,4÷20 mA			
	4÷20 mA	4÷20 mA	4,32÷20 mA			
	-20÷0÷20 mA	-20÷0÷20 mA	-19,2÷+20 mA			
Voltage	0÷75 mV	0÷75 mV	1,5÷75 mV	100	-	
	0÷100 mV	0÷100 mV	2÷100 mV			
	-100÷0÷100 mV	-100÷0÷100 mV	-96÷+100 mV			
	0÷10 V	0÷10 V	0,2÷10 V			
	-10÷0÷10 V	-10÷0÷10 V	-9,6÷+10 V			

* – one unit of the last category expressed in the percentage of a range of measurements

** – by the separate order

2.2. The limit of an admitted variation does not exceed a limit of an admitted basic error.

2.3. The time of the set of operating conditions (preliminary warming up) is no more than 30 mines.

2.4. The limit of the admitted additional error caused by change of the temperature of the air from the normal (20 ±5) °C till any temperature in limits (minus 10... + 60) °C for each 10 °C of temperature changes, does not exceed 0,5 limits of an admitted basic error.

2.5. The limit of the admitted additional error for the configuration with TC, caused by the temperature change of their loose ends in the range (-10 ÷ +60) °C, does not exceed a limit of an admitted basic error.

2.6. The limit of the admitted additional error caused by the influence of the increased humidity (till 95 % at 35 °C), does not exceed 0,5 limits of the basic error.

2.7. The limit of the admitted additional error caused by the change of the voltage of power from the nominal (220 V) in the limits (187...242) V, does not exceed 0,5 limits of an admitted basic error.

2.8. The limit of the admitted additional error caused by the influence of the constant magnetic fields and (or) variable fields of network frequency intensity till 400 A/m does not exceed 0,5 limits of the admitted basic error.

2.9. The limit of the admitted additional error caused by the influence of the voltage of a cross handicap of an alternating current with effective value, equal 50 % of the maximal value of the electric input signal working between the input measuring clips consistently with a useful signal and having any phase corner, does not exceed 0,5 limits of an admitted basic error.

2.10. The limit of the admitted additional error caused by the influence of the voltage of a longitudinal handicap constant or an alternating current with effective value, equal 100 % of the maximal value of the electric input signal working between any measuring clip and the earthed case and having any phase corner, does not exceed 0,5 limits of an admitted basic error.

2.11. The limit of the admitted additional error of ИРТ 1730 D/M and during the influence of vibration does not exceed the limit of the admitted basic error.

2.12. The area of the set settings corresponds to the range of measurements.

2.13. The limit of the admitted basic error of operation of the signal system does not exceed the limit of the admitted basic error of the sizes being measured.

2.14. The limit of the admitted additional error of operation of the signal system caused by the change of air temperature from the normal till any one within the limits of working temperatures for each 10 °C of the temperature changes, does not exceed 0,5 limits of an admitted basic error of operation of the signal system.

2.15. The limit of an admitted additional error of operation of the signal system caused by the change of the voltage of power from the nominal till any one within the limits of operating conditions of application, does not exceed 0,5 limits of an admitted basic error of operation of the signal system.

2.16. The zone of return at the operation of the settings is programmed in limits from 0 till 100 % from the range of measurements.

2.17. The range of the output unified signal of the MBC 0÷5, 0÷20, 4÷20 mA.

2.18. The limits of the admitted basic errors of the MBC for confirmations with RT or output signals as force and voltage of a direct current equal to $\pm(0,2k + 0,2)$ and the MBC for

configurations with TC - $\pm(0,5k + 0,2)$ at the resistance of loading $R_H = 1 \text{ k Ohm}$ for output $0 \div 5 \text{ mA}$ and $R_H = 0,2 \text{ kOhm}$ for output $0 \div 20$ and $4 \div 20 \text{ mA}$, abbreviation k – is a coefficient equal to the relation of ranges of measurements of IPT 1730D/M and the MBC.

2.19. The limit of the admitted additional error of the MBC, caused by changing of the air temperature from normal till any one in the limits of the working temperatures for each $10 \text{ }^\circ\text{C}$ of changing of the temperature, doesn't exceed 0,5 limits of an admitted basic error of the MBC.

2.20. The limit of the admitted additional error of the MBC, caused by a resistance deflection of loading from the limiting value $R_{\text{пред}} = 1,5 \text{ kOhm}$ for output $0 \div 5 \text{ mA}$ and $R_{\text{пред}} = 0,4 \text{ kOhm}$ for output $0 \div 20$ and $4 \div 20 \text{ mA}$ on minus 25 %, no more than 0,5 limits of the admitted basic error.

2.21. The limit of the admitted additional error of the MBC, caused by changing of voltage of power from nominal (220 V) in the ranges (187 ÷ 242) V, doesn't exceed 0,5 limits of the admitted basic error.

2.22. The set time of the output signal of the MBC (the time during which the output signal of the MBC goes into the limit zone of the admitted basic error) must not exceed 10 seconds.

2.23. Powering of IPT 1730D/M is executed from the alternating current network with frequency $(50 \pm 1) \text{ Hz}$ and voltage $(220^{+22}_{-33}) \text{ V}$.

2.23.1. The output characterises of the built-in stabilizer of voltage 36 V:

- voltage of idling $(36 \pm 0,72) \text{ V}$;
- voltage at the current of loading 22 mA $(36 \pm 0,72) \text{ V}$;
- the maximal current of loading 24mA.

2.23.2. The output characterises of the built-in stabilizer of voltage 24 V:

- voltage of idling $(24 \pm 0,48) \text{ V}$;
- voltage at the current of loading 22 mA $(24 \pm 0,48) \text{ V}$;
- the maximal current of loading 24mA.

2.24. The power, consumed by IPT 1730D/M from an alternating current network at the nominal network voltage, does not exceed $15 \text{ V} \cdot \text{A}$.

2.25. The limiting test voltage, the test specifications, the checked electric circuits, the points of the appendix of the test voltage (the connected together contacts of the other circuit) correspond to the given ones in table 2.3.

Table 2.3

Temperature, the relative humidity	Test voltage, V	Chains being checked	Numbers of contacts
(20 ± 5) °C 30÷80 %	1500	The power chain of the alternative current about: 1) case; 2) electrical chains of the signal system; 3) input chains; 4) output chains; 5) interface chains The electrical chains of the signal system among themselves The listed electrical chains according to items 2)...5) on the case	17,18 - 16 17,18 – 19, 20, 21 17,18 – 22, 23, 24 17,18 –1, ...15 19, 20, 21 – 22, 23, 24 16 – 19, 20, 21 16 – 22, 23, 24 16 – 1, ...15 1, ...7 – 8, ...15
(20 ± 5) °C 30÷80 %	500	The interface and output chains, output and input chains (among themselves)	1...5 – 6, 7 8, 9 – 10, ...15

2.26. The electrical resistance of the isolation of the current carrying circuits of IPT 1730D/M on the case and itself not less:

- 20 MOhm at the air temperature of (20 ± 5) °C and the relative humidity from 30 up to 80 %;
- 5 MOhm at the air temperature of (60 ± 3) °C and the relative humidity from 30 up to 80 %;
- 1 MOhm at the relative humidity (95 ± 3) % and the air temperature (35 ± 3) °C.

2.27. Overall dimensions, mm, no more:

Front panel	96 x 48 (on DIN 43700);
Cut in the board	88 x 45;
Assembly depth	210.

2.28. Weight of IPT 1730D/M is no more than 1,2 kg.

2.29. IPT 1730D/M is steady and solid against influencing of the air temperature from minus 10 up to + 60 °C and from minus 50 up to +50 °C accordingly.

2.30. IPT 1730D/M is steady and solid against the humidity influence up to 95 % at the temperature +35 °C and up to 98 % at the air temperature +35 °C accordingly.

2.31. IPT 1730D/M has durability and stability to influencing the wave vibration sine in the range of frequencies from 1 up to 100 Hz at the amplitude of vibro-acceleration 20 m/sec².

2.32. IPT 1730D/M has no constructive elements and units with resonant frequencies from 5 up to 25 Hz.

2.33. IPT 1730D/M has durability and stability to influencing of mechanical impacts of the single action with a peak shock acceleration of 20 m/sec², duration of a shock pulse from 2 up to 20 ms and the total of impacts equal to 30.

2.34. IPT 1730D/M has durability and stability to influencing of mechanical impacts of the repeated action with a peak shock acceleration of 30 m/sec^2 , with preferable duration of the shock acceleration action 10 ms (the admitted duration is from 2 up to 20 ms) and the number of impacts in each direction 20,

2.35. IPT 1730D/M has durability to influencing of shock jolting with the number of impacts 80 per minute, average quadratic value of acceleration 98 m/sec^2 and duration of influencing 1 hour.

2.36. IPT 1730D/M has durability at the seismic influences equivalent to the vibration influence with the parameters, specified in table 2.4.

Table 2.4

Frequency, Hz	1,0	2,0	3,0	4,0	5,0	6,0	8,0	10,0	15,0	20,0	30,0
Acceleration, m/sec^2	6,0	15,0	29,0	51,0	48,0	43,0	38,0	31,0	20,0	19,0	14,0

2.37. The maintenance of the electromagnetic compatibility and the noise immunity.

2.37.1. IPT1730D/M corresponds to execution group III on stability to electromagnetic handicaps in accordance with all-Union State Standard P 50746-2000.

IPT 1730D/M satisfies to the quality criterion of functioning A at the influence of handicaps in accordance with all-Union State Standard P 50746-2000.

2.37.2. IPT 1730D/M normally functions and does not create any handicaps in conditions of teamwork with the equipment of systems and elements for which it is intended, and also with the equipment of other use, which can be used together with data of IPT 1730D/M a in typical handicap situations.

3. Completeness

Table 3.1 - The complete set of the delivery of ИРТ 1730D/M

Name	Designation	Quantity	Execution variant		Note
			Output stabilized voltage, V	Interface type	
1. Measuring instrument - technological regulator (universal milli -voltmeter) ИРТ 1730D/M	НКГЖ.411618.003-05.00	1	24	RS 232	The execution variant according to the order
	НКГЖ.411618.003-05.01	1	36	RS 232	
	НКГЖ.411618.003-05.02	1	24	RS 485	
	НКГЖ.411618.003-05.03	1	36	RS 485	
2. Accessories			24 36	RS 232 RS 485	The one for the group of devices according to the order
2.1. Equaliser	НКГЖ.405111.001	1			
2.2. Block of labels (the units of the sizes being measured)	НКГЖ.301412.030	1			
2.3. Socket EC381V-07P		1			
2.4. Socket EC381V-08P		1			
2.5. Socket 2ESDV-12P		1			
2.6. Interface cable	НКГЖ.685631.025	1		RS 232	
3. The complete set of the software on compact disc (in the cartridge)	НКГЖ.411969.001	1			
4. The complete set of assembly parts					
4.1. Arm	НКГЖ.301569.001	2			
5. Box	НКГЖ.735316.001-01	1		RS 232 RS 485	
6. Box	НКГЖ. 735316.001	1			The one for the group of devices according to the order
7. Measuring instrument - technological regulator (universal milli -voltmeter) ИРТ 1730D/M. Manual	НКГЖ.411618.003-05ПС	1			

4. The device and its operation

4.1. IPT 1730D/M contains:

- a transformer power unit with pulse stabilizers;
- a two-element RC filter;
- a filter of suppression of the MICROWAVE of handicaps;
- an analog-digital converter (ADC);
- the microprocessor block;
- the module of the current output;
- two executive relays of system of the signal system;
- the module of interface RS 232 or RS 485;
- the indication and keyboard module .

4.1.1. The power unit of IPT 1730D/M transforms voltage 220 V into stabilized +5 V or +24V, powering the microprocessor, the interface, the ADC, the MBC and the built-in voltage stabilizer. The power switch is not stipulated, as IPT 1730D/M is intended for work in a non-stop mode.

4.1.2. The two-element RC filter provides a high noise stability of IPT 1730D/M.

4.1.3. The filter of suppression of the MICROWAVE of handicaps provides the electromagnetic compatibility of IPT 1730D/M with broadcasting appliances.

4.1.4. ADC transforms the input current analog signal to a code acting in the microprocessor.

4.1.5. The microprocessor block carries out the following functions:

- computes the current value of the sizes being measured by the results of the interrogation ADC expects;
- operates the module of indication, i.e. deduces the current measured size or edited parameter on the indicator;
- interrogates the keyboard;
- operates the scaled LED the indicator;
- operates the interface model.

4.1.6. The executive relays are operated by the microprocessor and switched on at the output of the size being measured beyond the limits of the bottom and top settings.

4.1.7. The interface module is intended for connecting with a computer.

4.2. The front panel of IPT 1730D/M is given in picture 4.1.

Measuring instrument - technological regulator
(universal milli-voltmeter)
ИРТ 1730D/M

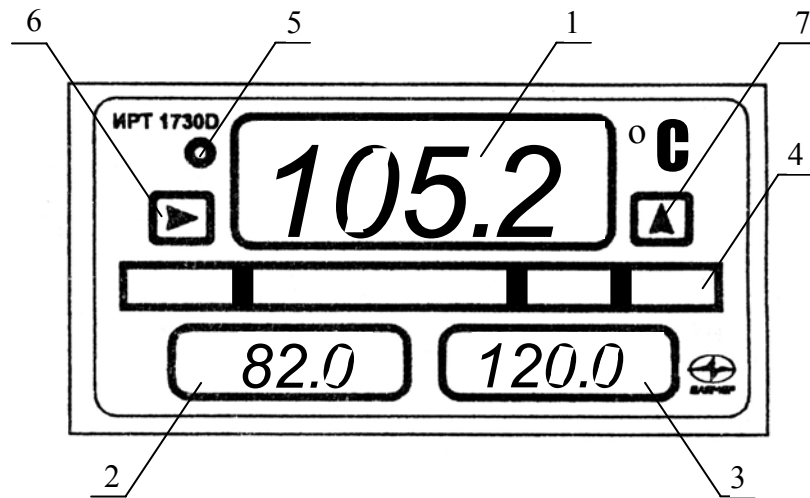

Picture 4.1.

4.3. The module of indication and keyboard include (according to picture4.1):

- 1 - the LED four-digit indicator of the size being measured;
- 2 - the LED four-digit indicator of setting I;
- 3 - the LED four-digit indicator of setting II;
- 4 - the scaled indicator of the size being measured position in relation to the settings;
- 5 - button of changing of ИРТ 1730D/M configuration;
- 6 - button ">" is an option of the edited category;
- 7 - button "^" is changing of the chosen category and an option of the following parameter.

Note. The configuration parameters are displayed on the indicators of positions 1, 2, 3 in the adjustment mode, according to item 4.3.3.2.

The scaled indicator

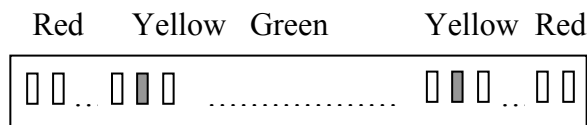

Picture 4.2.

The scaled indicator is divided into three zones:

- 1) the first one – the five positions of the red color,
- 2) the second one – the twenty-one position of the green color in dependence on the scale symmetry;
- 3) The third one – the five positions of the red color.

The first, second and third zones are divided among themselves by the non-stop luminous yellow individual indicators.

The position of the reflection of the lightbeam in the second zone (of the green color) corresponds to not emergency value of the size being measured.

The output in first and third (the zones of the red color) corresponds to a failure on the bottom and top setting accordingly, i.e. when a size being measured is less or more the top setting.

At the moment of an output of the parameter being measured from a zone of normal work (the green color) in a zone of failure (red color) begins to blink (with the frequency of 2 Hz) the appropriate digital indicator of the setting.

In case, if the size being measured is going beyond the limits of the scaled indicator, then the appropriate outside scale LED gets blinking with frequency 2 Hz.

4.3.2. The button of configuration changing enables the user to enter the menu of installation of configuration of IPT 1730D/M and to make the unitary changing of it.

It is necessary to keep the specified button in the pressed condition for the entering the menu until on the bottom indicators will not be highlighted "**PASS**". If not to press the button during 1 minute, then IPT 1730D/M automatically passes into the measurement mode.

4.3.3. The enter of any parameters including passwords.

4.3.3.1 The one-time pressing the button ">" of the choice of the edited category moves the blinking category of the indicator to the right. The one-time pressing the button "^", changes the edited category to the unit or chooses the following parameter if there are no blinking categories.

Before choosing of the configuration parameter, it is necessary to enter the password by the ways of the specified buttons. The opportunity of the password changing is stipulated only from the computer. The figures from 0 till 9 and the letters: A, b, C, d, E, F are used.

Factory installation of passwords is "**0000**".

4.3.3.2. The parameters of the configuration and their designation

1) "**Un**" – is the network number due to which IPT 1730 D/M responds to the inquiry of the computer. The values of the network numbers are from 1 till 254. If the number which is not appropriate for the specified range, it means that the indicator will show the message "**Err3**", indicating a mistake at the setting of the value parameter. After the expiration of 2 seconds it is possible to enter a new number.

The editing of parameters is carried out with the aid of the buttons ">" and "^", the value is shown in the right indicator.

Factory installation is "**Un**" = "**1**".

2) "**SPd**" – is the speed of transferring on the serial port RS 232/RS485.

The speed of the transferring gets out of the line: "0,3"; "0,6"; "1,2"; "2,4"; "4,8"; "9,6"; "19,2" kbits/sec.

Factory installation is "SPd" = "9.6".

3) "ind1" is the indication mode of settings. The given parameter provides two modes of operation with settings:

"1" – is the values of the settings which are always displayed on indicators;

"0" – if any of the settings hasn't worked, the values of the settings are turned off.

Factory installation is "ind1" = "1".

4) "ind2" – is the indication mode of the value being measured. The given parameter provides two modes of operation of the indicator of the value being measured:

"1" – the value being measured is always shown on the indicator;

"0" – if any of the settings hasn't worked, the indicator of the value being measured is turned off.

Factory installation is "ind2" = "1".

5) "AErr" – is the parameter determining the condition of the relay at an error of measurements (the breakage of an input circuit, the wrong connection of the initial converter etc.); The symbol of the specified parameter and the appropriate conditions of the relay are given in table 4.1

Table 4.1

Value of paramter "AErr"	Relay	
	setting I	setting II
0	off	off
1	on	off
2	off	on
3	on	on

Factory installation is "AErr" = "0".

6) "OUEr" – is the parameter determining the work of ИРТ 1730D/M beyond the measurements (only for the unified input signals as voltage or force of a direct current);

"OUEr" = "0" - the blinking inscription "-AL-" is displayed on the LED indicator of the size being measured, and the condition of the relay is defined by parameter "AErr";

"OUEr" ="1" - on the basic indicator the blinking inscription has "-OU-", and the condition of the relay is defined by the measured value.

Factory installation is "OUEr" = "0".

7) "tY" – is the mode of the operation of the settings:

"tY" = "0" – is setting I - lower, setting II - upper;

"tY" = "1" - both settings are lower;

"tY" = "2" - both settings are upper.

Factory installation is "tY" = "0".

8) "dAt" – is the symbol of an output signal (the initial converter with the unified output signal).

The designations of the initial converters, displaying in the right window IPT 1730D/M, correspond to the given ones in table 4.2.

Table 4.2.

Type designation of the initial converter or input signal	Symbol HCX	W_{100}	Range of measurements
"Cu85"	50M	1,4280	-50÷200 °C
"Cu65"	50M	1,4260	-50÷200 °C
"Cu81"	100M	1,4280	-50÷200 °C
"Cu61"	100M	1,4260	-50÷200 °C
"PtH5"	50Π	1,3910	-50÷600 °C
"PtH1"	100Π	1,3910	-50÷600 °C
"Ptb1"	Pt100	1,3850	-50÷600 °C
"HA"	XA(K)	-	0÷1300 °C
"HE"	XK(L)	-	0÷600 °C
"ΠΠ"	ΠΠ(S)	-	0÷1700 °C
"8P"	BP(A)-1	-	0÷2500 °C
"Pr"	ΠP(B)	-	300÷1800 °C
"t11"	-	-	-1÷0÷1 mA
"t01"	-	-	0÷1 mA
"t55"	-	-	-5÷0÷5 mA
"t05"	-	-	0÷5 mA
"t220"	-	-	-20÷0÷20 mA
"t020"	-	-	0÷20 mA
"t420"	-	-	4÷20 mA
"U075"	-	-	0÷75 mV
"U010"	-	-	0÷100 mV
"U110"	-	-	-100÷0÷100 mV
"U01"	-	-	0÷10 V
"U11"	-	-	-10÷0÷10 V

Factory setting – "**t020**".

9) "**Lc**" – is the connection circuit of RT according to picture A. 1 of appendix A:

"**c2**" – two-wire;

"**c3-**" - three-wire with the total minus;

"**c3p**" - three-wire with the total plus.

Factory installation "**c3-**".

10) "**Sqrt**" – is the function of the extraction of a square root.

If "**Sqrt**" = "**0**" – then the dependence of the size being measured on the input signal is linear and the indexed value, at the measurement of current or voltage, is calculated under the formula

$$\text{Value} = (\text{dP2} - \text{dP1}) \times \left(\frac{I - I_{\min}}{I_{\max} - I_{\min}} \right) + \text{dP1} \quad (4.1)$$

Abbreviation **Value** – is the value displayed on the indicator;

I – is the measured value of current or voltage;

Imin, Imax – are the limits of converting of the input signal in accordance with table 4.2;

dP2, dP1 – is the converting range according to item 4.3.2.15).

If "**Sqrt**" = "**1**" – then the dependence of the size being measured on the input signal – with a function of extraction of a square root and the indexed value, at the measurement of current or voltage, are calculated under the formula

$$\text{Value} = (\text{dP2} - \text{dP1}) \times \sqrt{\frac{I - I_{\min}}{I_{\max} - I_{\min}}} + \text{dP1} \quad (4.2)$$

Factory installation is "**Sqrt**" = "**0**".

11) "**Sil**" – is the function of the linearization of a square root near to zero. It is used for reduction of noise, but increases an error. The value of the parameter specifies in percentage of an input (being measured) range. The option out of the following fixed values: "**0,0**"; "**0,5**"; "**1**"; "**2**"; "**3**" % - is possible.

In the range of an output signal from 0 till of the chosen value function will be linear.

The value of "**0,0**" % - means, that this function is switched off, i.e. the function of a square root will be extracted in the whole range of input signals.

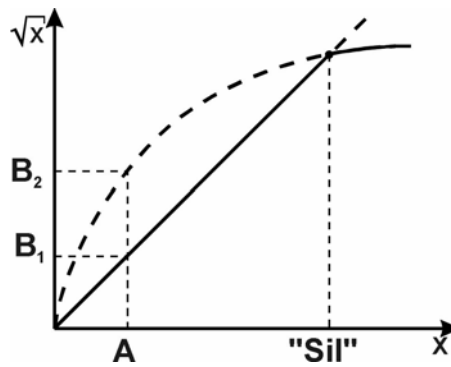

Picture 4.3

Table 4.3

Parameter value Sil, %	Input signal in the point of the maximal error A, %	Maximal error (B ₂ - B ₁), %
"0,5"	0,125	1,77
"1,0"	0,25	2,5
"2,0"	0,5	3,54
"3,0"	0,75	4,33

Factory installation is - **"0,0"** %.

12) **"nSU"** - the number of averagings of the measured signal values. Parameter changes from 1 to 255. In case of value 1, function of averaging is disconnected. This parameter increase enables to decrease the noise of the measured signal, but it increases considerably settings operating time at sharp change of input signal.

Factory setting: – **"1"**.

13) **"CutE"** - Open circuit failure signaling.

"CutE"="0" – switched off;

"CutE"="1" – switched on.

Parameter operates only with the following types of input signal:

«Voltage –100÷0÷100 mV»;

«Voltage 0÷100 mV»;

«Voltage 0÷75 mV».

Factory setting: – **"0"**.

14) **"UF"** – the number of marks after comma.

The quantity of marks after comma from 0 till 3.

The range of the indexed values at “**UF**” equal:

"3" - 0÷+9.999;

"2" - minus 9.99÷99.99;

"1" - minus 99.9÷999.9;

"0" - minus 999÷9999.

The value is shown in the right indicator.

Factory installation is – “**1**”.

15) "**GIST**" – is a hysteresis size. The size of a hysteresis is expressed in the same units, as the size being measured.

For the upper setting:

- at the increase of the value being measured, the relay is switched on at the reach of the setting value ;
- at the reduction of the value being measured, the relay is switched off at the value being measured value equal: a setting minus a hysteresis.

For the lower setting:

- at the reduction of the value being measured, the relay is switched on at the reach of the setting value;
- at the increase of the value being measured of the relay is switched off at the measured value equal to a setting plus a hysteresis.

Factory setting is "**GIST**" = "**0**".

16) "**IOdP**" – is the range of the output-unified signal of the measuring built-in converter MBC. The option out of three values of the parameter: "**0-5**", "**0-20**", "**4-20**" mA is possible, which are displayed on the indicator (see position 3 of picture figures 4.1).

Factory installation - "**0-5**" mA.

17) "**dP**" – is a transformation range.

For input signals as force or voltage of a direct current: a minimal value of the transformation range is displayed on the left display window (the value of indication appropriate to a minimum of the input range), a maximal value of the transformation range is displayed on the right display window.

Factory installation: min. - "**0.0**"; max.- "**100.0**".

18) "**Crn**" - is a transformation range for the input signal of the MBC, a value appropriate to the minimum of the output range is displayed on the left display window (an indication value,

appropriate to the minimum of the output range, in terms of the size being measured), a value appropriate to the maximum of the output range is displayed on the right display window.

Factory installation, min - **"0.0"**, max.- **"1.0"**.

19) **"rLn"** – is the line resistance at measuring of RT under the two-wire circuit, and also a the line resistance for the remote equalizer of cold seal of the thermocouples. On the left indicator, the line resistance is shown in Ohms, and one the right indicator - in the 100-th longs of Ohm .

Factory installation - **" 0.00"**.

20) **"r0"** – the RT resistance or the equalizer of a cold seal at the measure of TC in 0 °C, expressed in Ohms. If the value of this size is less 8 Ohm then this parameter is not used, and HCX is used in calculations of the set type of the initial converter (item 4.3.3.2.8)), (at the measurements of TC, the factory installation of HCX of the equalizer of a cold seal corresponds to Pt100 (W100=1,3850) and may not be changed by a user).

Factory installation - **"0.00"**.

21) **"dt"** – is the size of the linear displacement of the scale. To the calculated value by results of measurements value of parameter **"dt"** increases, and the result deduces on the indicator. The relay and the scaled indicator are established according to the new value.

Factory installation - **"0.0"**.

22) **"AL4"** –is the minimal measured size for the range 4...20 mA. The value of parameter is set in mill amperes. At the input signal, by the smaller value of this parameter, the message on breakage of the gauge will be given out.

Factory installation -is **"2.5"**.

Note. The parameters and their symbols are given in item 4.3.3.2. Some parameters cannot be displayed while viewing the menu, if they are not used with the set type of the initial converter.

4.3.3.3. Error messages

If any failures or malfunctions turn out to appear in IPT 1730D/M on the basic board (position 1, picture 4.1) the message on an error appear.

The possible error messages:

"Err0", **"Err1"**, **"Err4"** – an error in the internal memory of the device, the reason only eliminates industrially.

"**Err2**" - one of the parameters of the configuration of the device, or the discrepancy of the parameter "**UF**" (the quantity of marks after comma) and is incorrectly set by any numerical parameter.

"**Err3**" – the value if the entered parameter doesn't correspond to the allowed range.

In case of appearing of any of the set forth above errors, the device is automatically given: The device number- **0**, The exchange speed - **9600** baud.

After elimination of the reasons, which have caused an error, the values of these parameters, restore.

"**-AL-**" – is a breakage of the input circuit of the initial converter or going out the value of the size being measured out of the limits set for the given type of the initial converter.

"**-0U-**" – is the value going out of the limits of the size being measured, set for this type of the initial converter.

"**----**" is the number, which cannot be deduced on the 4th digit indicator. It's recommend to reduce the parameter "**UF**" (the quantity of marks after comma).

4.4. On the back panel of IPT 1730D/M are located:

- a terminal block for connection IPT 1730D/M to network and executive devices;
- a terminal block for connection of the input initial converter and the output of the voltage stabilizer 24 or 36 V;
- a terminal block for connection of the interface and the MBC output.

5. Instruction of security measures

5.1. ИРТ 1730D/M corresponds to class I according to all-Union State Standard 12.2.007.0-75 and satisfies to the safety requirements according to all-Union State Standard 51350-99.

5.2. ИРТ 1730D/M has a clip of the protective grounding in accordance with all-Union State Standard 12.2.007.0-75.

5.3. The initial converters, (for ИРТ 1730D/M with the initial converters), the executive devices are connected according to the mark at the switched - off voltage of power.

5.4. ИРТ 1730D/M is fireproof, the possibility of being a fire in ИРТ 1730D/M doesn't exceed 10^{-6} per one year according to all-Union State Standard 12.1.004-85, i.e. at any malfunctions arising both in ИРТ 1730D/M and in the external electric circuits connected to it, it is not a source of ignition.

5.5. It is necessary for follow the guidelines while operating of ИРТ 1730D/M НП-001-97 (ОПБ-88/97), ПНАЭ Г-1-024-90 (ПБЯ РУ АС-89), all-Union State Standard 12.3.019-80, " The guidelines of technical operation of electro installations of consumers ", " Safety precautions regulations while operating of consumers' electro installations", and " The guidelines of the device of electro installations ", authorized by Gosenergonadzor.

6. Preparation for work

6.1. Unpack IPT 1730D/M. Examine IPT 1730D/M, it must correspond to the following requirements:

- 1) IPT 1730D/M must be completed according to section 3 of this manual;
- 2) The factory number on IPT 1730D/M must correspond to the specified number in the manual;
- 3) IPT 1730D/M mustn't have any mechanical damages when its operation is inadmissible.

6.2. The installation order of IPT 1730D/M

6.2.1. It is necessary to have access from the backside of the board for fixing IPT 1730D/M in the board.

6.2.2. The electric circuit of IPT 1730D/M connections with the power network, the initial converter, the executive devices of the signal system, carried out through the terminal block, located on the back panel, is given in picture A1 of appendix A.

6.2.3. To ground the case of IPT 1730D/M, to plug. After the expiration of 30 minutes, IPT 1730D/M is ready to work.

6.3. Approbation

6.3.1. To check the zeros to IPT 1730D/M for the RT configuration, one is to connect a store of resistances, for the TC configuration - the comparator of voltages by means of a calibration cable or to place the converter thermoelectric into an ice-water mix.

To set the resistance values of the resistances 50 Ohm for RT such as 50M, 50П and 100 Ohm - for RT such as 100M, 100П, Pt 100.

Set the zero value on the voltage comparator of the thermal electromotive force.

6.3.2. To connect the sources of the calibrated currents and voltages accordingly to the inputs of IPT 1730D/M for the configurations with input electrical signals as force and voltage of a direct current.

To set the values of the input signals appropriate to the top limits of the size being measured.

6.4. If necessary to make configuration of IPT 1730D/M, using instructions of chapter 4.

7. Operating procedure

7.1. Connect the initial converter to IPT 1730D/M connect the executive devices under the circuit given in picture A.1 of appendix A.

7.2. Connect IPT 1730D/M to the power supply. After the expiration of 30 minutes of IPT 1730D/M is ready to work.

7.3. Set the setting values due to the buttons, for this operation you should:

- press the button ">", at this moment the word "PASS" appears;
- enter the access password for settings, using instructions of chapter 4; if the password is entered correctly, then the one-time change is allowed for changing of the settings.

8. Technique of check

8.1. The checking of IPT 1730D/M is served by the bodies of the State metrological service or the metrological service of the consumer having the checking rights.

The requirements for the checking, the order, the basic stages of realization of checking are defined by ИП 50.2.006-94" ГСИ. The checking of means of measurements. The organization and the order of realization "

8.2. The Intertesting interval is - 2 years.

8.3. Operations and means of checking

8.3.1. One executes the operations specified in table 8.1 at the conduction of checking.

Table 8.1

№ item	Operation of checking	Number of item	Compulsion of the operation conducting	
			At initial checking	At periodic checking
1.	Examination	item 8.6.1	+	+
2.	Approbation	item 8.6.2	+	+
3.	Checking of the electric isolation resistance	item 8.6.3	+	-
4.	Checking of the electric isolation durability	item 8.6.4	+	-
5.	Defining of the values of the basic errors of the measuring channel*	item 8.6.5.1-8.6.5.5	+	+
6.	Defining of the values of the basic error of the MBC *	item 8.6.5.6	+	+
7.	Defining of the output characteristics of the built-in voltage stabilizer.	item 8.6.5.7	+	+

* It is allowable to define the basic errors of the measuring channel and the MBC to conduct for a concrete configuration according to item 8.8 at a consumer's request.

8.3.2. The basic and auxiliary means of checking are applied specified in table 8.2 at the conduction of checking.

Table 8.2.

Name of checking means and number of reference document	Basic metrological and characteristics of checking means
Calibrator- the measuring instrument of the unified signals, standard ИКСУ-2000 ТУ 4381-031-13282997-00	Range of the resistance reproduction 0...180 Ohm, 180...320 Ohm. Basic error $\pm 0,015 \text{ Ом}$, $\pm 0,025 \text{ Ом}$. Range of the temperature reproduction (RT) Minus 200...600 °C. Basic error $\pm 0,05 \text{ °C}$. Range of the temperature reproduction (TC) Minus 210...1300 °C. Basic error $\pm 0,3 \text{ °C}$. Range of the temperature reproduction Minus 10...100 mV, 0...12 V. Basic error $\pm (7 \cdot 10^{-5} \cdot U + 3) \text{ мкВ}$, $\pm 3 \text{ мВ}$ Range of the current reproduction 0...25 mA. Basic error $\pm (10^{-4} \cdot I + 1,5) \text{ мкА}$.
Resistors	C2-23-1,0-1,1 kOhm-5 %; C2-29B-0,25-1,5 kOhm-1 %- A
	C2-23-1,0-1,6 kOhm-5 %; C2-29B-0,25-100 Ohm- 0,1 %- A
	C2-29B-0,25-390 Ohm-1 %- A
Ruler all-Union State Standard 427-75	Division size 1 mm
Disruptive fixing УИУ-1М	Voltage 1500 V
Megaohmmeter Ф4102/1-1М ТУ 25-7534.005-87	Measuring range 0...20000 MOhm.

Note. It is supposed to apply means of separate checking, newly developed or being in use and the equipment, keeping up with the characteristics specified in the current technique of checking.

8.4. Safety requirements

8.4.1. One execute the safety requirement, given in the documentation of the applied means of checking and the equipment.

8.5. Checking conditions and preparation for it

8.5.1. It is necessary to follow the following conditions:

- | | |
|---|------------------------------------|
| 1) Temperature of the air, °C | 20 \pm 5; |
| 2) Relative humidity of the air, % | 30 \div 80; |
| 3) Atmospheric pressure, kPa (mm of a hg) | 84,0 \div 106,7;
(630 - 800); |
| 4) Power voltage, V | 220 \pm 4,4; |
| 5) Frequency of the power line, Hz | 50 \pm 0,5. |

8.5.2. All operations, being conducted with means of checking and ИРТ 1730D/M being checked, are executed according to the instructions given in the operational documentation.

8.5.3. One executes the following spadework before conducting of checking.

8.5.3.1. ИРТ 1730D/M is to be kept for 4 hours set in item 8.5.1.

8.5.3.2. The checking means are prepared for work according to the operational documentation.

8.6. Realization of checking

8.6.1. Examination of IPT 1730D/M being checked is executed according to item 6.1 of the current manual.

8.6.2. Approbation of IPT 1730D/M being checked is in checking of its serviceability according to item 6.3 of the current manual.

8.6.3. Checking of the isolation electrical resistance

8.6.3.1. Checking of the electrical isolation resistance of IPT 1730D/M is conducted by megaohmmeter Φ 4102/1-1M or some other device for measuring of electrical resistance with working voltage not exceeding 500 V and an error no more than 20 %.

The readout of indications is conducted after the expiration of 1 minute after attaching if the voltage between the contacts of the tested circuit connected together and the case (a clip of protective grounding) or the contacts of some other circuit connected together according to table 8.3.

Table 8.3

Test voltage, V	Chains being checked	Numbers of the contacts united in groups according to picture A.1 of appendix A	
		first	second
500	The power circuit of an alternating current, the electrical circuits of the signal system on: 1) Cases (of the clip of the protective grounding)	Terminal block «Network»: contacts 17, 18; All contacts of the signal system: Channel 1 – Channel 2: contacts 19 - 24	Case (a clip of the protective grounding)
	2) of the output interface chains and output chains of the MBC	RS232/RS485: contacts 1-5;	Output of the MBC: contacts 6, 7
	3) of the output chains of the built-in voltage stabilizer and the output chains of the measuring channel	Output of the source 24/36 V: contacts: 8, 9;	Clips of input K1 – K6: contacts 10 - 15

Resistance of the isolation must not be less than 20 MOhm.

8.6.4. Checking of the electrical isolation durability

8.6.4.1. Checking of the electrical isolation durability is conducted on the set YIIY-1M, allowing to increase voltage smoothly or in regular steps, not exceeding 10 % of the value of the test voltage.

The test voltage should be raised smoothly, from zero or from the value not exceeding the nominal circuit voltage to the test one for 5 - 10 seconds, but no more than 30 seconds. Decreasing of the voltage to zero should be made with the same speed.

The measuring error of the test voltage must not exceed ± 5 %.

The values of the test voltage for the various circuits of IPT 1730D/M are specified in table 8.4.

Table 8.4.

Test voltage, V	Chains being checked	Numbers of the contacts united in groups according to picture A.1 of appendix A	
		first	second
1500	The power circuit of an alternating current the electrical circuits of the signal system on: Case (of the protective grounding clip)	Terminal block «Network»: contacts 17,18; All contacts of the signal system: Channel 1 – Channel 2: contacts 19 - 24	Case (a clip of the protective grounding)
	Of the output circuits of the built-in voltage stabilizers and the input circuits of all measuring channels and interface circuits		contacts 8 – 15; RS232/RS485: contacts: 1 - 5
500	Interface and output chains	RS232/RS485: contacts: 1 - 5	Output of the MBC: contacts: 6, 7

The isolation is kept under the action of the test voltage within 1minut. Then the voltage is smoothly decreased to zero or the value, not exceeding nominal, after the test set is disconnected.

There must be no breakdowns and superficial blocking of the isolation during checking.

8.6.5. Defining of the values of the basic errors of the measuring channel, the MBC and the output characteristics of the built-in voltage stabilizer

8.6.5.1. Defining of the values of the errors of the measuring channel of IPT 1730D/M can be conducted as independently (with use of keyboard of IPT 1730D/M for its configuration and the indicators of IPT 1730D/M for data read-out), and with the aid of the IBM (with use of the IBM keyboard for IPT 1730D/M configuration and the IBM screen for data read-out).

8.6.5.2. To define the error values of IPT 1730D/M, working with the resistance thermoconverters (RT) and the input signals as resistance to a direct current, one executes the following operations:

- 1) connect IBM (while using it) to IPT 1730D/M and launch the appropriate program;
- 2) plug IPT 1730D/M and keep it in this condition for 30 minutes;
- 3) set the following configuration of IPT 1730D/M (the configuration parameters and their designation correspond to item 4.3.3.2):
 - setting I = "0,0";
 - setting II = "1,0";

- indication of the settings "ind1" = "1";
- indication of the value being measured "ind2" = "1";
- symbol of the input signal
(of the initial converter with the unified-
output signal) "dAt" = "Pt100";
(Pt100, W=1.385);
- connection circuit of RT in accordance
with picture A 1 of appendix A: "Lc" = "c3-"
(3 wire with the common minus);
- quantity of marks after comma "UF" = "1";
- resistance of RT or the equalizer
of a cold seal at measuring of TC,
expressed in Ohms "r0" = "0.00";
- range of transformation for the output
signal as force of a direct current "Crn" = ("0.0"; "5.0");
- size of the linear scale displacement "dt" = "0.0".

Values of other parameters may be any ones.

4) Power the calibrator ИКСУ-2000 (further - ИКСУ), prepare it for work in a mode of emulation of the temperatures appropriate to the input signals from RT such as Pt100 and connect it to the input of ИРТ 1730D/M under a three-wire circuit with the common minus;

5) Set the emulated value with the aid of ИКСУ (valid A_{δ}), temperature value-50,0°C (appropriate to the signal of ИРТ 1730D/M, given to the input, 80,31 Ohm in accordance with all-Union State Standard 6651-94) and make measurements of ИРТ 1730D/M being checked;

6) Define the value of the absolute error ΔA as a difference of the measured and valid values of the size being measured under the formula

$$\Delta A = A_{изм} - A_{\delta}, \quad (8.1)$$

Abbreviation $A_{изм}$ – is the measured value of the size (temperature) in the point being checked;

7) repeat the operations of items 8.6.5.2.5)...8.6.5.2.6), serially setting the emulated (valid) values of temperatures with the aid of ИКСУ equal 160,0 °C (161,05 Ohm) and 550,0 °C (297,49 Ohm), and make the appropriate measurements of ИРТ 1730D/M being checked;

8) set the configuration of ИРТ 1730D/M being checked for the input signals from RT such as 50II according to item 4.3.3.2:

- symbol of the input signal
(the initial converter with the unified
output signal) "dAt" = "PtH5"
(50II, W=1.391);

Values of other parameters must correspond to item 8.6.5.2.3).

9) Switch ИКСУ in a mode of emulation of the temperatures appropriate to the input signals from RT such as 50П;

10) Repeat the operations according item 8.6.5.2.5) ... 8.6.5.2.6), serially setting the emulated (valid) values of temperatures with the aid of ИКСУ equal -50,0 °C (40,00 Ohm); 160,0 °C (81,01 Ohm) and 550,0 °C (150,33 Ohm), and also make the appropriate measurements of ИРТ 1730D/M being checked;

11) Disconnect ИКСУ off the input of ИРТ 1730D/M and get sure that there are “-AL-“ symbols on the green screen of ИРТ 1730D/M (the control of breakage of the input circuit of the initial converter or the output of the value of the size being measured for the limits set for the given type of the initial converter).

8.6.5.3. To define of the values of ИРТ 1730D/M basic errors with the input signals as voltage of a direct current in the range -100...100 mV and with input signals from the TC, one executes the following operations:

1) Prepare ИКСУ for work in a generation mode of the constant voltage of the millivolt range and connect it to the input of ИРТ 1730D/M, thus the polarity of ИРТ 1730D/M connection must be changed on opposite;

2) set the following parameters of ИРТ 1730D/M configuration (the configuration parameters of the configuration and their designation correspond to item 4.3.3.2):

- setting I = "0,0";
- setting II = "1,0";
- indication of the settings "ind1" = "1";
- indication of the value being measured "ind2" = "1";
- symbol of the input signal
(the initial converter with the unified output signal) "dAt" = "U110"
(Voltage -100...+100 mV);
- quantity of marks after comma "UF" = "2";
- transformation range for the output signal
signal as force of a direct current "Crn" = ("0.00"; "5.00");
- function of extraction of a square root "Sqrt" = "0";
- transformation range "dP" = ("0.00"; "50.00");
- size of the linear displacement of the scale "dt" = "0.00".

Values of other parameters may be any ones.

3) set the value of the emulated (valid) voltage with the aid of ИКСУ equal +100 mV, and make the appropriate measurements ИРТ 1730D/M being checked (the valid value of the size being measured is defined under the formula (4.1));

4) Define the value of the absolute error as a difference of the measured and valid values of the size being measured under the formula (8.1);

5) Change the polarity of ИКСУ connection;

6) Set the following configuration for ИРТ 1730D/M:

- symbol of the input signal
(the initial converter with the unified output signal)

"dAt" = "U010"
(Voltage 0... + 100mV).

Values of other parameters must correspond to 8.6.5.3.2).

7) Repeat the operations of items 8.6.5.3.3), 8.6.5.3.4), serially setting the values of the emulated (valid) voltage by the measuring-calibration instrument ИКСУ, equal 0, 25, 50, 75 and 100 mV, make the appropriate measurements of ИРТ 1730D/M being checked (the valid value of the size being measured, one defines under the formula (4.1)).

8) Set the following ИРТ 1730D/M configuration:

- setting I = **"0,0"**;
- setting II = **"1,0"**;
- indication of the settings
- indication of the value being measured
- symbol of the input signal
(the initial converter with the unified output signal)

"ind1" = "1";
"ind2" = "1";

- quantity of marks after comma
- resistance of the line for the remote equalizer of a cold seal of the TC
- resistance of the RT or the equalizer of a cold seal at measuring of the TC, expressed in Ohms
- transformation range from the output signal as force of a direct current
- size of the linear displacement of the scale **"dt" = "0"**.

"dAt" = "HA"
(ТП XA (K));
"UF" = "0";

"rLn" = "0.00".

"r0" = "0.00";

"Crn" = ("0"; "5";

Values of other parameters may be any onea.

9) Connect the equalizer of a cold seal to ИРТ 1730D/M in an emulation mode of the TC signals such as TXA XA (K), and keep ИРТ 1730D/M in this condition for 30 minutes;

10) Serially setting the values of the emulated (valid) temperatures by the measuring instrument – calibrator ИКСУ, equal 0 and 1300 °C, make the appropriate measurements of ИРТ 1730D/M being checked; define the value of the absolute error as a difference of the measured and valid values of the size being measured under the formula (8.1);

11) set the following ИРТ 1730D/M configuration:

- symbol of the input signal
(the initial converter with the unified

output signal)

"dAt" = "ПП"
(ТТ ПП (S))

(at the customer's request according to the note to table 2.1).

Values of other parameters must correspond to item 8.6.5.3.8).

12) Disconnect ИКСУ off ИРТ 1730D/M input, connect the resistor S2-29V - 100 Ohm to ИРТ 1730D/M instead of the equalizer, put ИКСУ in the emulation mode of ТТ ПП (S) with the internal indemnification, connect ИКСУ to ИРТ 1730D/M;

13) Serially setting the values of the emulated (valid) temperatures by the measuring instrument – calibrator ИКСУ, equal 0 and 1700 °C, equal 0 and 1700 °C, make the appropriate measurements of ИРТ 1730D/M being checked; define the value of the absolute error as a difference of the measured and valid values of the size being measured under the formula (8.1).

8.6.5.4. To define the values of the basic error while working with ИРТ 1730D/M with the input signals as voltage of a direct current in the range $-10...10$ V, one executes the following operations:

1) Prepare ИКСУ for working in the generation mode of the constant voltage of a volt range and connect it to the input of ИРТ 1730D/M, thus the connection polarity of ИРТ 1730D/M must be changed on opposite;

2) Set the following parameters of ИРТ 1730D/M configuration (parameters of the configuration and their designation correspond to item 4.3.3.2):

- symbol of the input signal
(the initial converter with the unified
output signal)

"dAt" = "U11"
(Voltage) -10 ... +10V;

Values of other parameters must correspond to item 8.6.5.3.2).

3) set the value of the emulated (valid) voltage with the aid of ИКСУ, equal +10 V (the valid value of the size being measured, one executes under the formula (4.1));

4) define the value of the absolute error as a difference of the measured and valid values of the size being measured under the formula (8.1);

5) Change the polarity of ИКСУ connection;

6) set the following ИРТ 1730D/M configuration:

- symbol of the input signal
(the initial converter with the unified
output signal)

"dAt" = "U01"
(Voltage) 0...+10 V;

Values of other parameters must correspond to item 8.6.5.3.2).

7) Serially setting the values of the emulated (valid) voltages by the measuring instrument – calibrator ИКСУ equal 0 and 10 V, make the appropriate measurements of ИРТ 1730D/M being checked; define the value of the absolute error as a difference of the measured and valid values of the size being measured under formula (8.1)

8.6.5.5. To define of the values of the basic error working with ИРТ 1730D/M with the input signals of a direct current, one executes the following operations:

1) Prepare ИКСУ for working in the generation mode of the constant voltage and connect it to the input of ИРТ 1730D/M, thus the polarity of ИРТ 1730D/M connection must be changed on opposite;

2) set the following configuration of ИРТ 1730D/M:

- symbol of the input signal
(the initial converter with the unified output signal)

"dAt" = "t220"
(Current -20...+ 20 mA);

Values of other parameters must correspond to item 8.6.5.3.2).

3) Set the value of the emulated (valid) current with the aid of ИКСУ that equal +20mA (the valid value of the size being measured, one defines under the formula (4.1));

4) Define the value of the absolute error as a difference of the measured and valid values of the size being measured under the formula (8.1);

5) Change the polarity of ИКСУ connection;

6) Set the following configuration for ИРТ 1730D/M:

- symbol of the input signal
(the initial converter with the unified output signal)

"dAt" = "t020"
(Current 0... + 20 mA).

Values of other parameters must correspond to item 8.6.5.3.2).

7) Serially setting the values of the emulated (valid) temperatures by the measuring instrument – calibrator ИКСУ equal 0 and 20 mA, make the appropriate measurements of ИРТ 1730D/M (the valid value of the size being measured, one defines under the formula under formula (4.1);

8) Set the following configuration for ИРТ 1730D/M:

-setting I = **"0.0"**;
- setting II = **"1.0"**;
- indication of the setting
- indication of the value being measured
-symbol of the input signal
(the initial converter with the unified output signal)

"ind1" = "1";
"ind2" = "1";
"dAt" = "t05"
(Current 0... + 5 mA);

- quantity of marks after comma "UF" = "3";
- function of extraction of a square root "Sqrt" = "0";
- transformation range for the output signal as force of a direct current "Crn" = ("0.000"; "5.000");
- transformation range "dP" = ("0.000"; "5.000");
- size of the linear displacement of the scale "dt" = "0.000".

Values of other parameters are left without changes.

9) Serially setting the values of the emulated (valid) current by the measuring instrument – calibrator ИКСУ, equal 0 and 5 mA, make the appropriate measurements of ИРТ 1730D/M being checked.

8.6.5.6. To define the basic error of the MBC channel of ИРТ 1730D/M, one executes the listed operations:

- 1) Prepare ИКСУ for working in the measurement current mode;
- 2) Connect consistently the connected inputs of ИКСУ and the resistor 1,5 kOhm to plugs 6 and 7 of ИРТ 1730D/M being checked;

3) Set the following configuration for ИРТ 1730D/M:

- range of transformation "dP" = ("0.000"; "0.000");
- range of the output unified
- signal of the converter of the measuring built-in MBC "IOdP" = "0-5"
(Current 0-5mA).

Values of other parameters must correspond to item 8.6.5.5.8).

4) Measure the value of the output current and define the value of the absolute error as a difference given in the parameter "dP" and the measured valid values of the output current under formula (8.1);

5) set consistently the values of the parameters of ИРТ 1730D/M configuration "the transformation range "dP", equal accordingly ("2.500"; "2.500"), ("5.000"; "5.000") and carry out item 8.6.5.6.4);

6) Connect consistently the inputs of ИКСУ and the resistor 390 Ohm to plugs 6 and 7 of ИРТ 1730D/M being checked;

7) Set the following configuration for ИРТ 1730D/M according to item 4.3.3.2:

- setting I = "0.0";
- setting II = "1.0";
- indication of the settings "ind1" = "1";
- indication of the measured value "ind2" = "1";
- symbol of the input signal
- (the initial converter with the unified output signal) "dAt" = "t020";
(Current 0... + 20 mA);
- quantity of marks after a comma "UF" = "2";

- range of transformation for the output signal as force of a direct current
- function of extraction of a square root
- range of transformation
- range of the output unified signal of the measuring built-in MBC

"Crn" = ("0.00"; "20.00");
 "Sqrt" = "0";
 "dP" = ("0.00"; "0.00");

"IOdP" = "0-20"
 (0...20 mA);
 "dt" = "0.00".

- size of the linear displacement of the scale

Values of other parameters are left without changes.

8) Measure the value of the output current and define the size of the absolute error as a difference given in the parameter "dP" and the measured valid values of the output current under formula (8.1).

9) Set consistently the values of the parameter of IPT 1730D/M configuration "the transformation range "dP", equal accordingly ("4.00"; "4.00"), ("12.00"; "12.00"), ("20.00"; "20.00") and carry out the operations of item 8.6.5.6.4).

8.6.5.7. Defining of the output characteristics of the built-in voltage stabilizer

- 1) prepare ИКСУ for working in the measuring voltage mode;
- 2) connect ИКСУ to plugs 8 and 9 tested IPT 1730D/M;
- 3) measure the value of the output voltage and define the value of the absolute error ΔU as a difference of the measured $U_{изм}$ and the nominal U_H of the values of the output voltage:

$$\Delta U = U_{изм} - U_H \quad (8.2)$$

- 4) connect the resistor 1,6 Ohm to plugs 8 and 9 of the product being tested for the nominal voltage 36 V or the resistor 1,1 Ohm for the nominal voltage 24 V.
- 5) repeat the operations according to item 8.6.5.7.3).

8.7. Processing results of checking

8.7.1. Whiling checking of IPT 1730D/M, the calculated values of the absolute errors for the RT Pt100 must not exceed:

- ±0,6 °C - for the points being checked -50,0 °C (80,31 Ohm); 160 °C (161,05 Ohm);
- ±1,6 °C - for the points being checked 550 °C (297,49 Ohm).

8.7.2. While checking of IPT 1730D/M, the calculated values of the absolute errors for the RT 50II must not exceed:

- ±0,6 °C - for the points being checked -50 °C (40,00 Ohm); 160 °C (81,01 Ohm);
- ±1,6 °C - for the points being checked 550 °C (150,33 Ohm).

8.7.3. The values of the absolute errors for the input signals as voltage of a direct current in the range -100 ... + 100 mV for the point being checked -100 mV must not exceed:

$\pm 0,4$ mV (on the input signal);
 $\pm 0,1$ (under the indicator indications in
the units of the size being measured).

8.7.3.1. The values of the absolute errors for the input signals as voltage of a direct current in the range $-100 \dots + 100$ mV for the points being checked 0, 50, 100 mV must not exceed:

$\pm 0,15$ mV (on the input signal);
 $\pm 0,07$ (under the indicator indications of
the units of the size being measured).

8.7.4. The values of the absolute errors for the TC must not exceed:

For TII XA (K) - $\pm 6,5$ °C;
For TII III (S) - $\pm 8,5$ °C.

8.7.5. The values of the absolute errors for the input signals as voltage of a direct current in the range $-10 \dots + 10$ V for the point being checked -10 V must not exceed:

± 40 mV (on the input signal);
 $\pm 0,1$ (under the indicator indications in
the units of the size being measured).

8.7.5.1. The values of the absolute errors for the input signals as voltage of a direct current in the range $-10 \dots + 10$ V for the points being checked 0, 10 V must not exceed:

± 20 mV (on the input signal);
 $\pm 0,1$ (under the indicator indications in
the units of the size being measured).

8.7.6. The values of the absolute errors for the input signals as a direct current in the range $0 \dots + 5$ mA for the points being checked 0, 5 mA must not exceed:

$\pm 0,01$ mA (on the input signal);
 $\pm 0,010$ (under the indicator indications in
the units of the size being measured).

8.7.7. The values of the absolute errors for the input signals as a direct current in the ranges $-20 \dots + 20$ mA for the point being checked -20 mA must not exceed:

$\pm 0,08$ mA (on the input signal);
 $\pm 0,10$ (under the indicator indications in
the units of the size being measured).

8.7.7.1. The values of the absolute errors for the input signals as a direct current in the ranges $-20 \dots + 20$ mA for the points being checked 0, 20 mA must not exceed:

$\pm 0,032$ mA (on the input signal);
 $\pm 0,08$ (on the indicator indications in
the units of the size being measured).

8.7.8. While defining of the basic error of the MBC and the absolute errors of transformation must not exceed exceed:

- $\pm 0,032$ mA - for the output range 0...20 mA;
- $\pm 0,01$ mA - for the output range 0...5 mA.

8.7.9. While defining the output characteristics of the built- in voltage stabilizer, the absolute errors of measurement must not exceed:

- $\pm 0,72$ V for the nominal voltage 36 V;
- $\pm 0,48$ V for the nominal voltage 24 V.

8.7.10. IPT 1730D/M is considered to be kept according to items 8.6.5.1...8.6.5.5, if the measured absolute errors are in the limits specified in items 8.7.1... 8.7.7 (i.e. the values of the basic given errors do not exceed maximum permissible), and also the monitoring system of breakage of the gauge functions.

IPT 1730D/M is considered to be gone through the test according to item 8.6.5.6, if the measured absolute errors of transformation are in the limits specified in item 8.7.8.

IPT 1730D/M is considered to be gone through the test according to item 8.6.5.7, if the measured absolute errors of transformation are in the limits specified in item 8.7.9.

8.8. Defining of the values of the basic errors of the measuring channel and the MBC, configured for the concrete type of the input signal

8.8.1. The basic error of the measuring channel of IPT 1730D/M for the configurations with the RT and the TC (item 2.1, table 2.1) is defined in the points appropriate of 5, 25, 50, 75, 95 % of a range of measurements.

The nominal static characteristics of the RT transformation must correspond to all-Union State Standard 6651-94, the nominal static characteristics of the TC transformation must correspond to all-Union State Standard T P 8.585-2001.

Measurements for defining of the basic errors of the measuring channel of IPT 1730D/M with the specified configurations are conducted by the technique stated in items 8.6.5.2 and 8.6.5.3.

One calculates the basic error γ_1 under formula (8.3) in the each point being checked which is expressed as the given error in percentages of the normalizing value.

The normalizing value is defined as a difference of the top and bottom limiting values of the size being measured.

$$\gamma_1 = \frac{A_{u3M} - A_\partial}{A_\partial - A_n} \cdot 100\% \quad (8.3)$$

Abbreviation A_n, A_∂ - are the bottom and top limiting values of the range of measurements;

A_∂ - is the valid value of the size in the point being checked;

A_{u3M} - is the measured value of the size.

The most of the calculated values of the basic error must not exceed the values specified in table 2.1.

8.8.2. The basic error of the measuring channel of ИРТ 1730D/M for the configurations with the electrical input signals as force and voltage of a direct current (item 2.1, table 2.2) is defined in the points being checked appropriate of 5, 25, 50, 75, 95 % of the range of the input unified signal.

The measurements for defining of the basic errors of the measuring channel of ИРТ 1730D/M with the specified configurations are conducted by the technique stated in items 8.6.5.3, 8.6.5.4, 8.6.5.5.

The valid values of the sizes A_∂ being measured, appropriate to the values of the input signal in the points being checked, one calculates under formulas (8.4),... (8.7). For dependence of the size being measured on the input signal:

- linear

$$A_\partial = \frac{A_\partial - A_n}{I_\partial - I_n} \cdot (I_{ex.i} - I_n) + A_n, \quad (8.4)$$

$$A_\partial = \frac{A_\partial - A_n}{U_\partial - U_n} \cdot (U_{ex.i} - U_n) + A_n \quad (8.5)$$

- with function of extraction of a square root

$$A_\partial = \frac{A_\partial - A_n}{\sqrt{I_\partial - I_n}} \cdot \sqrt{I_{ex.i} - I_n} + A_n, \quad (8.6)$$

$$A_\partial = \frac{A_\partial - A_n}{\sqrt{U_\partial - U_n}} \cdot \sqrt{U_{ex.i} - U_n} + A_n, \quad (8.7)$$

Abbreviation $I_n, I_\partial, U_n, U_\partial$ - the bottom and top limiting values of the ranges of force and voltage of a direct current accordingly;

$I_{ex.i}, U_{ex.i}$ - the values of the input signal as force and voltage of a direct current in the point being checked accordingly.

The basic given error of the measuring channel is calculated under formula (8.3)

The most of the calculated values of the basic error of the measuring channel must not exceed the value specified in table 2.2.

8.8.3. Defining of the values of the MBC basic error, configured for the concrete type of the input signal.

Checking of the basic MBC error is made by the method of comparison of ИКСУ indications connected on the output of the MBC with the calculated (valid) value of the output signal.

The basic error is defined in the points appropriate of 5, 20, 40, 60, 80, 100 % of the range of changing of the output signal for the output from 0 up to 5 mA and 5, 25, 50, 75, 100 % of the range of changing of the output signal for the output from 0 up to 20 mA and from 4 up to 20 mA.

Defining of the basic MBC error values is conducted according to the technique given in item 8.6.5.6., configured for the concrete type of the input signal.

The basic given error of the measuring channel is calculated under formula (8.8) for the each point being checked.

$$\gamma_2 = \frac{I_{uzM} - I_{\partial}}{I_H} \cdot 100 \% \quad (8.8)$$

Abbreviation I_{uzM} -the value of the output current in the point being checked, measured ИКСУ;
 I_{∂} -the valid value of the output current in the point being checked;
 I_H - the normalizing value of the output signal equal 5 mA – for the output 0÷5 mA, 20 mA – for the output 0÷20 mA и 16 mA – for the output 4÷20 mA.

The most of the calculated values of the basic error must correspond to the requirements of item 2.18 of the current manual

8.9. Registration of the checking results

8.9.1. The positive results of ИРТ 1730D/M checking is completed with the certificate on the state checking of the set form according to ПП 50.2.006-94.

8.9.1.1. The results of ИРТ 1730D/M checking, configured for the concrete input signal is completed with the certificate on the state checking set form ПП 50.2.006-94 with the showing results of checking on its back (or a report of any form).

Attention! In this case it is not supposed to use ИРТ 1730D/M with other configurations.

8.9.2. It is not supposed to use ИРТ 1730D/M at the negative results of checking until finding out the reasons of malfunctions and their elimination.

8.9.3. After removing of the found out malfunctions, one conducts the repeated checking, the results of the repeated checking are final.

9. Guidelines of transportation and keeping

9.1. IPT 1730D/M is transported by all means of transport in covered vehicles. Fixing of container in vehicles should be made according to the guidelines working on the appropriate means of transport.

9.2. The conditions of IPT 1730D/M transportation must correspond to conditions 5 in accordance with all-Union State Standard 15150-69 at temperature of air from - 50 till + 50 °C with the following of the protection measures from impacts and vibrations.

9.3. The conditions of IPT 1730D/M keeping in a transport container in a warehouse of the manufacturer and the consumer must correspond to conditions 1 in accordance with all-Union State Standard 15150-69.

10. Certificate on packing

10.1. The measuring instrument - technological regulator (universal milli-voltmeter) ИРТ 1730D/M with factory number №_____ is packed by the research-and-production enterprise “ELEMER” according to the requirements established by the design documentation.

Date of packing _____

Seal.

Packing was made by _____

(signature)

11. Acceptance certificate

11.1. The measuring instrument - technological regulator (universal milli-voltmeter) IPT 1730D/M/ _____ / _____ with factory number № _____ is made and accepted according to the obligatory requirements of the state standards, working engineering specifications and recognized serviceable.

Chief Of The Quality Department

STAMP PLACE _____
Signature Signature decoding

Year, month, date

11.2 The results of the first checking (calibrating) of IPT 1730D/M are positive.

Date of checking (calibrating) _____

STAMP PLACE

Checker _____
(surname and signature)

12. RESOURCES, SERVICE LIFE AND SHELF LIFE MANUFACTURER'S GUARANTIES (SUPPLIER'S GUARANTIES)

12.1. The resource of the technological measuring control (general purpose millivoltmeter IPT 1730 D/M makes up 30000 hours within the 10 years service life. The above mentioned resource, service life and shelf life are valid only if a consumer follows the requirements of the operating in-line documentation.

12.2. Guaranties of the manufacturer (supplier).

12.2.1. The manufacturer guarantees correspondence of IPT 1730 D/M to the requirements of technical specifications, if only a consumer follows requirements of operation, storage, and transportation.

12.2.2. Warranty period of operation is determined to be 24 months from the selling date of IPT 1730 D/M.

12.2.3. In case of loss of effectiveness of IPT 1730 D/M, the device is repaired at the manufacturing factory at the address:

124460 Russia,
Moscow
Zelenograd, 1145, n/p 1
The research-and-production enterprise «Elemer»

Phone: (495) 925-5147

Fax: (499) 710-0001

E-mail: elemer@elemer.ru

